

# LANSEN

---

## USER MANUAL

---

LAN-WMBUS-GW5-M-LR-A1/A2-(X)-CATM1-(X)  
LAN-WMBUS-GW5-M-LR-A1/A2-(X)-CAT1/4G-(X)



## SYMBOLS:



Important information regarding instructions or recommendations for installation of devices.



Warning, risk for bodily harm if handled without care.

## NOTICE:



We are not responsible for any damage, malfunction, or non-compliance resulting from the use of unauthorized accessories or modifications to this device.



Do not attempt to alter or repair the device, if you are experiencing malfunction make sure to contact your place of purchase or visit our website.



It is recommended to use ESD protection to prevent potential damage to this product.

## WARNING:



Appropriate disconnection device, such as a power supply cable with socket, shall be used as part of the building instruction. It should be close to the device and easily accessible to the user. Furthermore, a 230 VAC installation **MUST** be carried out by an authorized installer (skilled person) according to the relevant electrical safety regulations.

## Additional information

Please note that SIM-card, antennas, and antenna cables are not included. See our full range of antennas, cables, and other accessories under our “accessories section” online. All articles listed can be found on our website: <https://www.lansen.io/assortment/accessories/>

Article Name	Description
LAN-WMBUS-D2-TC	Lansen Configuration Dongle
Lansen Configurator	Software for Lansen Dongle
LAN-CF-CABLE	Configuration Cable, USB
LAN-A-PMB-KIT-ID58-78	Pole mounting kit
LAN-MAG-R4	Magnet with telescopic shaft
LAN-R4-IP-KIT	Sealing kit for A1 enclosure
LAN-R4-AC_STRF-KIT	Strain relief kit for A1/A2 enclosure
LAN-ANT-868-HW-DP	868mHz Dipole antenna, SMA, 130mm
LAN-ANT-868-PR-3LW	868mHz antenna, outdoor use, 1,2 meters, 4dB gain
LAN-SMA-N-L300	SMA-to-N antenna cable, 300 cm
LAN-SMA-N-L100	SMA-to-N antenna cable, 100 cm
LAN-IPEX-SMA-IP-110	IPEX-to-SMA cable, 110 cm

## INTRODUCTION

The mains powered wM-Bus gateway is a highly configurable plug-and-play device used for collecting data from wM-Bus meters and transmitting the data using LTE-M1 and CAT1/4G. The enclosure is designed to make the gateway as discrete as possible.

For more information, go to our website at [www.lansen.io](http://www.lansen.io).

## LABEL INFORMATION

The label on the device gives necessary information about a specific device. See example below.

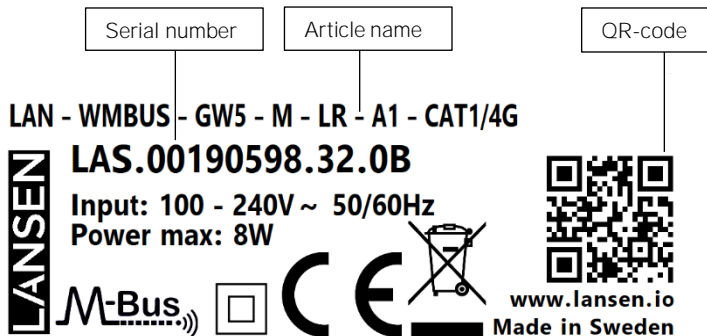

Identification number: Unique identification number for wM-Bus

QR-code: Full device information (example above: LAS.00190598.32.0B)

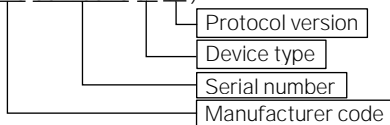

## SPECIFICATIONS

	wM-Bus	LTE CAT-M1	LTE CAT1/4G
Frequency band(s)	M: 868,000 MHz to 868,600 MHz  N: 868,700 MHz to 869,200 MHz	LTE-M B1/B2/B3/B4/B5/B8/B12/B13/B14/ B18/B19/B20/ B25/B26/B27/B28/B66/B85	LTE-FDD B1/B2/B3/B4/B5/ B7/B8/B12/B13/B18/ B19/B20/B25/B26/B28/B66/B71  LTE-TDD B34/B38/B39/B40/B41
Output power (ERP)	< 14 dBm / < 25 mW	20 or 23 dBm / 100 or 199,5 mW	23 dBm / 199,5 mW
Configurable	Yes, either with Lansen USB-Dongle, USB-C Cable, or from MQTT. For more information, refer to the configuration manual.		
Input voltage power	100 – 240V, 50/60Hz		
Max Power	8W		

### RECOMMENDED PLACEMENT INSTRUCTIONS:

- Mount preferably on walls, indoors and away from water. Can be mounted on ceilings (A1).
- Can be mounted on walls, ceilings, poles, pipes, and masts (A2).
- Keep at least 30cm in all directions to other objects or walls/ceiling/floor.
- The label on the device should be on the left side

IF X VERSION: The label on the device MUST be on the left side and the external SMA connection MUST point downwards for the device to be fully protected against water.

## MOUNTING INSTRUCTIONS

(A1) It is recommended to install the gateway indoors to a wall, but it can also be installed to the ceiling. It is highly recommended to mount the device as shown in the next image.

(A2) It is recommended to install the gateway upright on a wall, pole, pipe, or similar, but it can be installed on a ceiling as well. It is highly recommended to mount the device as shown in the next image.

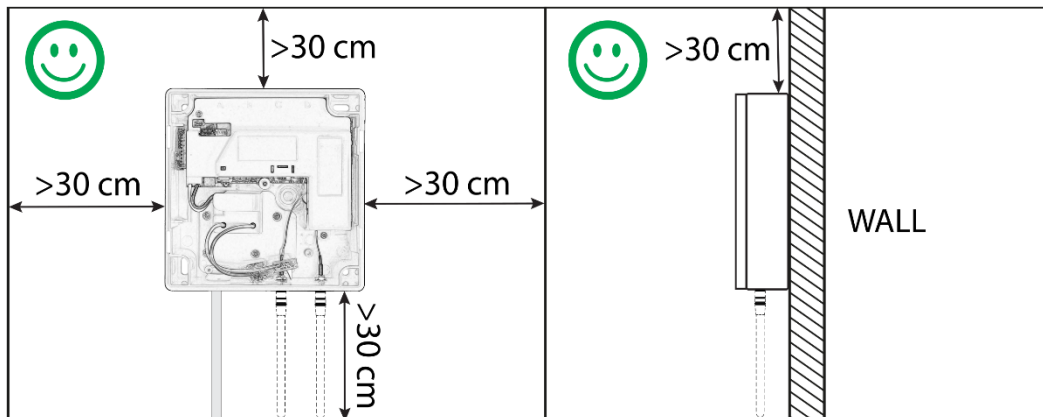

## Installing and mounting

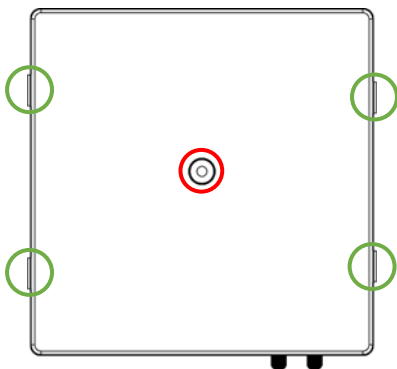

### Step 1:

Unscrew the screw (marked with a red circle on the image to the left) and remove the cover by pushing the clips at both sides of the cover.

**Note: The screw is a Security Torx T20H (with a small pin in the middle).**

## Step 2:

Note: Do not use the hole on the back for outdoor usage!

The power supply cable can be mounted either through the cable guide at the bottom or through the hole on the back. By using the hole on the back, the gateway can be mounted directly on an outlet to hide cables.

- If the hole at the back is going to be used, go to **Step 3**.
- If the cable guide on the side is going to be used, go to **Step 4**.

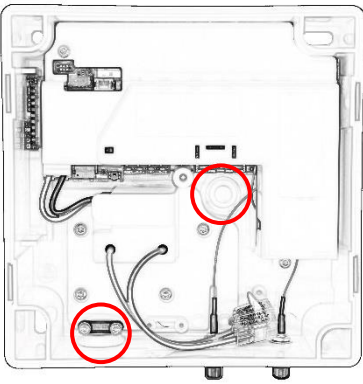

## Step 3:

Note: This solution gives IP-class 40. Do NOT use this for outdoor installations!

To use the hole in the back for a power supply cable, carefully cut, drill or punch out the hole marked in the picture to the left.

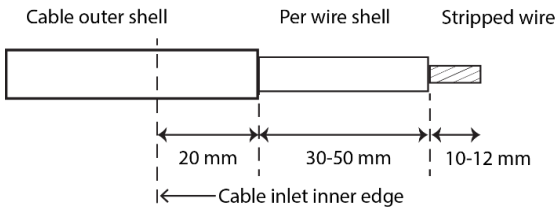
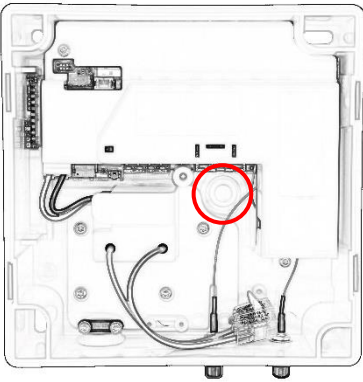

## Step 4:

Strip the power supply cables according to the diagram. Diameter for the cable when entered through the silicon grommet is:

Minimum 6mm.

Recommended 8mm.

Maximum 10mm.

### Step 5:

Thread the power supply cable (prepared in **Step 4**) through the cable inlet, either from the back of the gateway or on the side (marked by red circles). Connect the power supply cable to the coupling clamps on the inside (marked by blue circle).

**Note:** Use an awl to perforate the silicone grommet to guarantee a perfectly round hole.

**Note:** If using the cable guide on the side, make sure to use the strain relief which is included in the package.

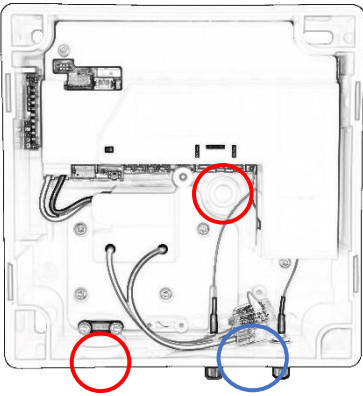

### Step 6:

Prepare to insert a SIM-card (not included) by removing the poke protection. Unscrew the two screws (red circles, Torx T10).

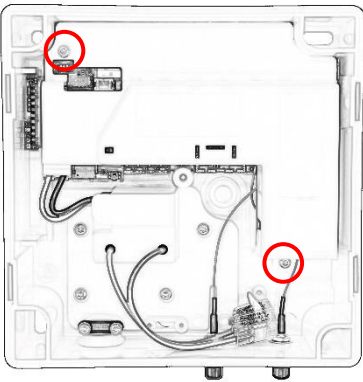

### Step 7:

With the poke protection removed, a nano sized SIM-card can be inserted into the SIM-card holder (red circle). Insert the SIM-card into the SIM-card holder by sliding it in.

**Note:** Make sure the orientation of the SIM-card is exactly as shown with the cut corner (red arrow) of the SIM-card in the correct way, otherwise the SIM-card will not have contact with the SIM-card holder.

**Note:** Make sure the SIM-card is not pushed in too far. This might cause it to not get picked up by the SIM-card holder.

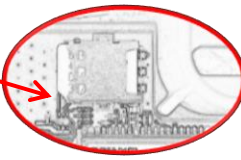
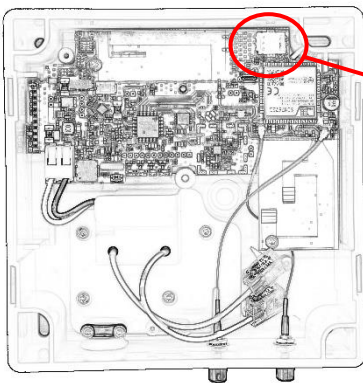



### Step 8:

Remount the poke protection and the screws (Torx T10), which were removed in **Step 6**, into the holes.

Depending on how the gateway is going to be installed, one must follow different mounting instructions:

- a. Mounting on a wall: Go to **Step 9**.
- b. Mounting on a pole or mast: Go to **Step 10**.

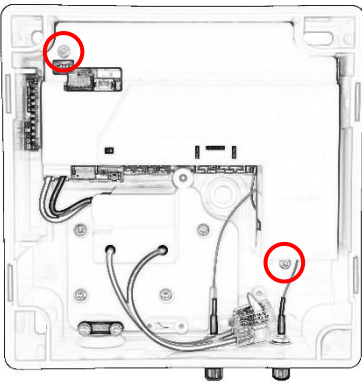

### Step 9:

Hold the gateway where it is going to be mounted. Mark the holes (red circles), pre-drill if necessary (depending on material), and mount the device by using four screws (not included). Continue to **Step 11**.

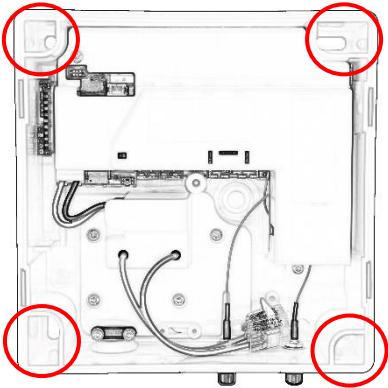

### Step 10:

Install the Lansen pole mounting kit (article number LAN-910-0066) on the back of the gateway. Pull the straps through the holes and wrap it around the pole or pipe which the gateway is going to be mounted on and tighten the straps, so it is securely mounted.

**Note: More detailed instructions with pictures will be available in next version of the installation guide!**

## Step 11: Startup sequence

**Note:** The LEDs in this step are located at the center of the device (red circle).

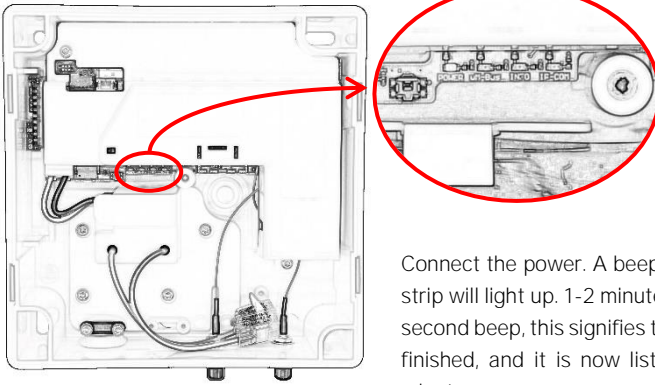

Connect the power. A beep will be heard and all 4 LEDs on the strip will light up. 1-2 minutes after the first beep you will hear a second beep, this signifies that the gateway startup sequence is finished, and it is now listening for packages, this takes 1-2 minutes.

Once it has listened for packages, the device will attempt to connect to the MQTT server, you can see this because the IP-COM LED will start flashing. For more information look at **Step 13** with its indication table.

## Step 12: Configuration of device.

During the first 3-4 minutes after the startup sequence is complete, the device accepts configuration data. We recommend connecting to the device using a Lanser USB-dongle (LAN-WMBUS-D2-TC) with the software *Lanser Configurator* during this time frame. Setup the gateway according to your needs and make sure to setup the MQTT server settings correctly, otherwise the gateway will be unable to upload data.

**Note:** If the gateway comes pre-configured with correct MQTT settings then there is no need to connect and configure the gateway.

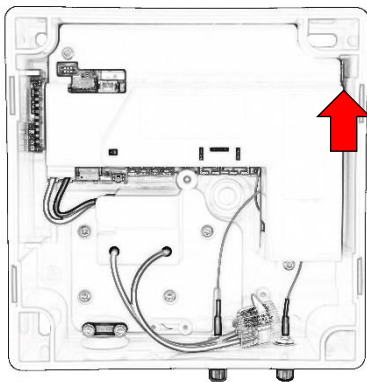

After approximately three minutes, the gateway will try to connect to a cellular network and upload data to an MQTT server. The gateway will indicate differently depending on the status to the cellular network using the LED in the upper right corner (red arrow). See **Step 13** for the meanings of the indications.

**Note:** It's important that all settings, especially the MQTT server settings, are entered correctly for the device to work properly.

**Note:** MQTT settings are company specific.

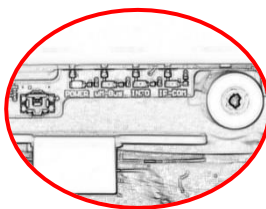
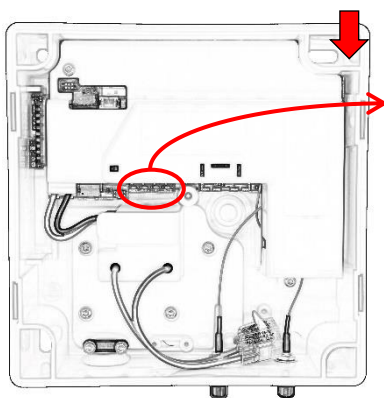

### Step 13: Indications

A gateway has two places with LEDs – One LED strip for status of the device (red circle) and one LED for status of cellular connectivity (red arrow). See next page for indication table.

LED Strip (red circle)			
POWER	Green	Steady on	The device has power.
POWER	Green	All steady on	Startup sequence active.
wM-Bus	Red		
INFO	Red		
IP-COM	Red		
wM-Bus	Red	Quick flash	New packet received by the wM-Bus radio.
INFO	Red	Steady on	wM-Bus radio on/listen for radio packets.
IP-COM	Red	Steady on	Active connection to the MQTT server.
		Blinking	Modem active but not connected to MQTT Server.
Cellular network LED (red arrow)			
Red	Flash every 300 ms (0.3 s)		The device is sending data.
Red	Steady on/off + flash every 300 ms (0.3 s) in intervals – Repeating this pattern.		Not registered to a network, rebooting, attempting to connect to a network.

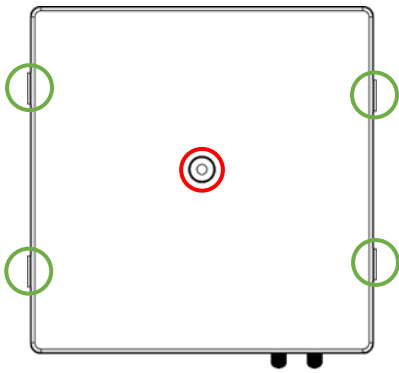

### **Step 14:**

Attach the cover and mount the screw (marked with a red circle on the image below). Make sure the clips at both sides of the cover are firmly attached.

**Note: The screw is a Security Torx T20H (with a small pin in the middle).**

### **Step 15:**

Some variants of the gateway support external antennas. Go to the corresponding step below depending on the variant you are installing (see label on the enclosure or poke protection).

#### **LAN-WMBUS-GW5-M-LR-A1/A2-CATM1:**

No further steps required; installation is now complete!

#### **External antenna for cellular network.**

Go to **Step 16**.

#### **External antenna for wM-Bus.**

Go to **Step 17**.

#### **External antenna for wM-Bus and cellular network.**

Go to **Step 18**.

## Step 16: Antenna for cellular network

This device supports an external antenna for transmitting using cellular to MQTT and uses an internal antenna to receive wireless M-Bus.

**Note: Make sure to use an external antenna operating in the frequency band used for your cellular network.**

**Note: Make sure to enable the parameter to use external antenna for cellular network by using Lansen Configurator or sending a command using MQTT.**

**Note: Use the RIGHT SMA connection for cellular antenna.**

Attach an external antenna to the device, either directly on the SMA connection (left picture below) or with an antenna cable (right picture below). Typically, smaller antennas are mounted directly on the SMA connection while larger antennas require being mounted upright and with an antenna cable.

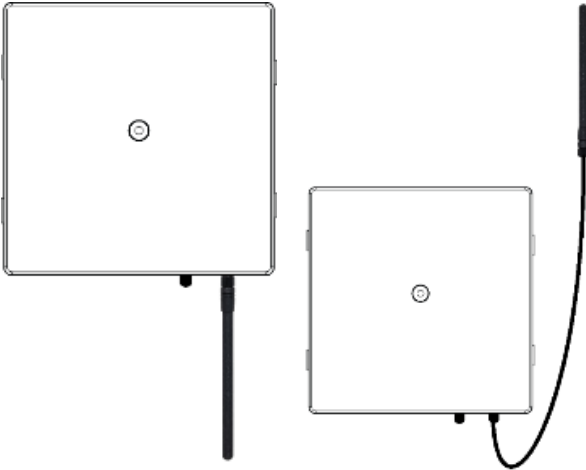

## Step 17: Antenna for wM-Bus

This device supports an external antenna for receiving wireless M-Bus and uses an internal antenna to transmit using cellular to MQTT.

**Note:** Make sure to use an external antenna operating in a frequency band suited for wM-Bus data (868 MHz).

**Note:** Make sure to enable the parameter to use external antenna for wM-Bus by using Lanser Configurator or sending a command using MQTT.

**Note:** Use the LEFT SMA connection for wM-Bus.

Attach an external antenna to the device, either directly on the SMA connection (left picture below) or with an antenna cable (right picture below). Typically, smaller antennas are mounted directly on the SMA connection while larger antennas require being mounted upright and with an antenna cable.

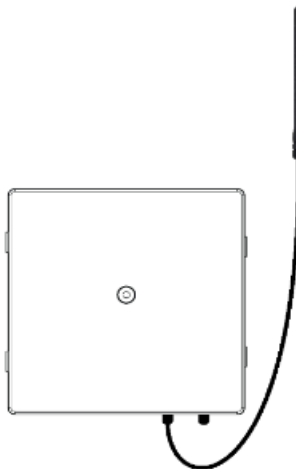

## Step 18: Antennas for wM-Bus and cellular network

This device supports external antennas for receiving wM-Bus and transmitting using cellular to MQTT.

Attach two external antennas to the device, either directly on the SMA connection or with an antenna cable. When using both external antennas we recommend placing them as far apart as possible (AT LEAST 50 CM) to avoid interference, either by using 2 antenna cables or attaching 1 directly on the device and 1 with a cable. Typically, smaller antennas are mounted directly on the SMA connection while larger antennas require being mounted upright and with an antenna cable.

**Note:** Make sure to enable the parameter to use both external antenna for wM-Bus and cellular data, e.g., by using Lansen Configurator.

**Note:** Use the LEFT SMA connection for wM-Bus and the RIGHT SMA connection for the cellular antenna.

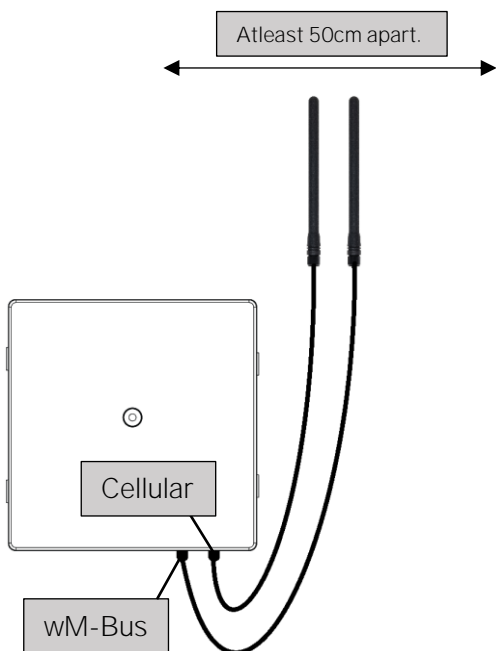

## GW5-M Hardware Troubleshooting

Issues	Possible Reason(s)	Possible Solution(s)
The device is not activating.	The device may not be powered properly.	<p>Make sure the cables are connected properly to the coupling clamps inside the device.</p> <p>Note: Make sure the power is off while attaching, detaching, or altering the power cables in the device.</p>
Lights.	Indicators.	<p>Please see <b>Step 13</b> in this user manual for the various indications the PCB card may provide.</p> <p>Note: If the IP-COM LED is only blinking the modem is active but not connecting to the MQTT server. Make sure the settings entered are correct.</p>
The device is activated but not relaying any information.	Coverage	Be aware that there may be dead zones when it comes to coverage, make sure the device is setup where there is coverage to the MQTT server.
	SIM-Card	<p>Make sure the SIM-card is LTE compatible.</p> <p>Make sure it is the correct SIM-card used for this device.</p> <p>Make sure the SIM-card has no PIN code, must be deactivated.</p> <p>Make sure the SIM-card is properly attached to the PCB card, see <b>Step 3</b>.</p>
	<p>The distance between gateway and repeater / sensor.</p> <p>Poor RSSI.</p>	<p>Too close: The device needs to be a minimum of 1 meter away from the active repeater / sensor(s).</p> <p>Not within range: If you have a wireless sensor or repeater, move it closer to the device to see if you need to close the gap with an additional repeater.</p>



The device is activated but not relaying any information.	<b>For X-versions:</b>	
Antenna / Antenna adapter.	Make sure the antenna (or antenna adapter towards the device) is a male connector.  Make sure the antenna is connected properly to the SMA contact.  If coverage is poor or you are not connecting to your MQTT server, try a stronger antenna. Remember <b>to alter the “Antenna gain”</b> if needed in Lansen Configurator.	

## GW5-M Software Troubleshooting

Issues	Possible Reason(s)	Possible Solution(s)
Wrong software, drivers or firmware for your dongle.	-	Visit our website for the latest software, drivers or firmware found at <a href="http://www.lansensystems.com/download/">www.lansensystems.com/download/</a>
Cannot configure the repeater by using the dongle.	Distance.	<p>Too close: The device may be too close to the dongle. Recommended distance is 1m away from the dongle.</p> <p>Not within range: The device may be too far away from the dongle. Move your computer closer to see if you can connect and check through packet sniffer when the device is within range.</p>
	ID.	Make sure your serial number "LAS.XXXXXXXXX.32.0B" (Example) where the Xs are the serial number, is added properly for the connection to work.
	Encryption.	If encryption is enabled, ensure the AES key provided to you on our website is correctly entered: <a href="http://www.lansenonline.com">www.lansenonline.com</a> .
	<p>Listen/Pause timer.</p> <p>Magnet/Reed timer.</p>	<p>Make sure the device is listening at the time you are either connecting or sending the configuration update.</p> <p>Note: You can force this by using a magnet to the left of the label of the device or disconnecting/connecting the power.</p> <p>Note: If you are using a magnet, or disconnecting/connecting the power, a red LED will light up and you will hear beeping.</p>
Heavy data trafficked areas.	Whitelisting, manually adding meters.	If you are setting up your gateway in a heavy data trafficked area you may wish to whitelist your devices. In <b>Lansen Configurator</b> , go to "Config Repeater / Bridge" and then the "Meters" tab. Remove "Automatic meter installation" as a parameter and add the meters manually under "Add meter data".

Issues	Possible Reason(s)	Possible Solution(s)
	Whitelisting, manufacturing ID.	If you are setting up your gateway in a heavy data trafficked area you may wish to whitelist your devices. In Lansen Configurator, go to “Config Repeater / Bridge” and then the “Routing” tab. Here you can manually add the manufacturing ID’s under “Accepted Manufacturing IDs”.
S-Mode.	S-Mode.	<p>Input mode: If you choose to put the device input mode to S-mode, once configured, be aware that you need the dongle to be reconfigured to S-mode as well before doing further changes.</p> <p>Output mode: You will not receive any data unless the dongle is configured to S-Mode, however, configuring the repeater will still be possible with the standard “T/C” configured dongle.</p>
Antenna.	Antenna Gain.	<p>Make sure when using an external antenna to modify (if needed) the Antenna Gain in Lansen Configurator to legal limits.</p> <p>This parameter can be found under the “Basic” tab.</p>
	Antenna	Make sure you are using the correct configuration for the antenna usage on your device. In Lansen Configurator you can alternate between using external antennas or internal antennas.
Programming through Lansen Configurator and MQTT.	MQTT.	<p>To configure the device via your MQTT server, the device must first be connected to the MQTT server which requires all MQTT settings to be set correctly. Also make sure the serial number from the device is put in correctly.</p> <p>Note: If you are using a dongle to configure the device, remember to use the AES key if encryption is enabled, or you can only view the parameters and only the first letter in the MQTT settings.</p>

Issues	Possible Reason(s)	Possible Solution(s)
Programming through Lansen Configurator and MQTT.	MQTT.	<p><b>Important:</b> Make sure that all settings are valid when changes are made on a device in a remote location. If the settings are incorrect then it will not be possible to do any more configurations using the MQTT interface.</p> <p>Make sure that all 4 settings are set correctly, MQTT host, username, password and port since they are sent in the same configuration packet to the gateway. Meaning if only 1 parameter is changed, the 3 other parameters are also changed to the current value in the GUI.</p>
Programming through Lansen Configurator and USB to USB-C cable (wired).	Cannot connect to the device.	<p>Make sure the device is started and the startup sequence is finished before attempting to connect via cable.</p> <p>Make sure you are using the latest Lansen Configurator 1.7.0.0, or wired connection is not supported.</p> <p>Important to note that the USB cable will be providing the device with power.</p>
Further questions.	-	For any further questions, please contact your place of purchase.

### SIMPLIFIED EU DECLARATION OF CONFORMITY

Hereby, Lansen Systems AB declares that the radio equipment type defined by article name on the sticker is in compliance with Directive 2014/53/EU. The full text of the EU declaration of conformity is available at the following internet address: <https://www.lansensystems.com/DOC>

